

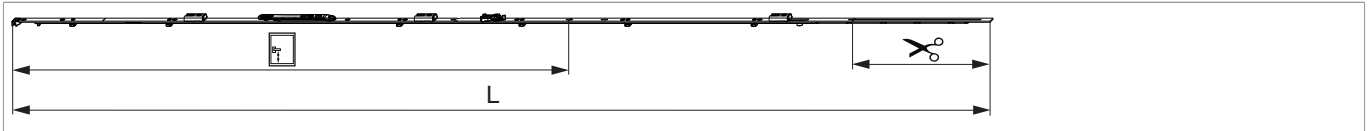

## 221907 - Stulpflügelgetriebe MM fix 1950 für 3 i.S. FFH 1.701-1.950 GM 1.050 Silber

### Technische Zeichnung



				<b>L</b>				<b>№</b>
Silber	für 3 i.S.	1950	1.050	1.846,5	1.701 - 1.950	260,5	10	221907

### Schraubpositionstabelle

<b>№</b>		1	2	3	4	5	6	7	8	9	10	11	12	13	14	15	16
221907	13	18,5	91,5	303,5	350	477	630	738,5	784,5	896	950	1.150	1.409	1.455			

### Stanzbild

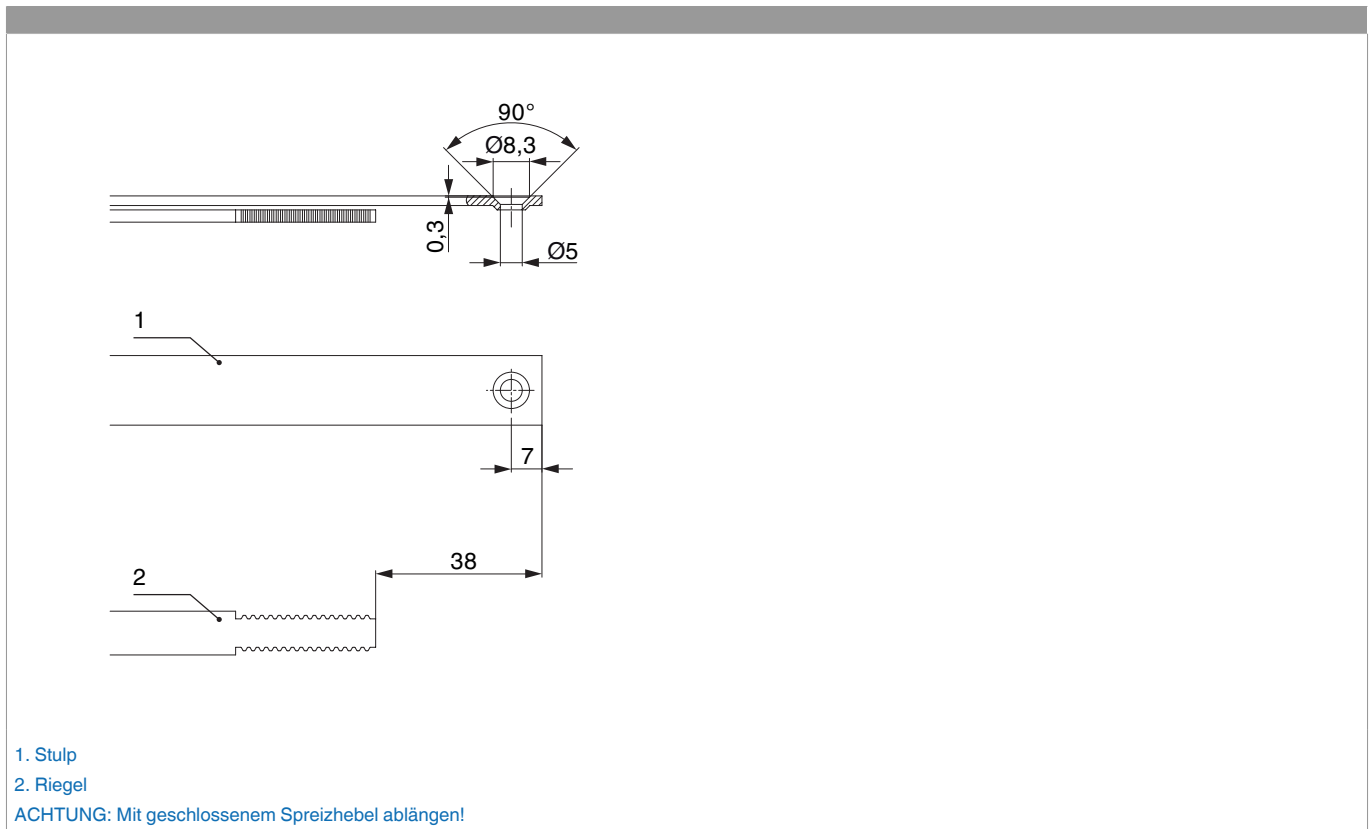



## Klipsverbindung

### Klipsverbindung einhängen

①

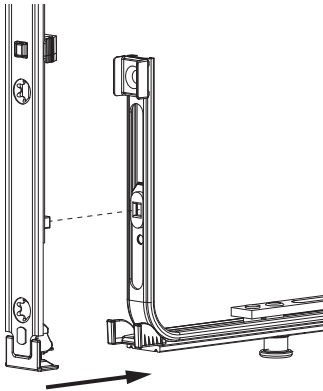

②

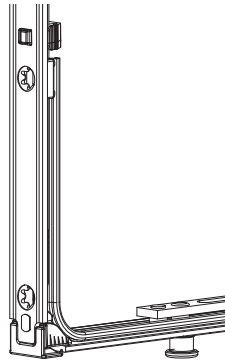

### Klipsverbindung aushängen

①

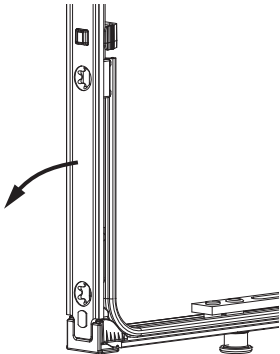

②

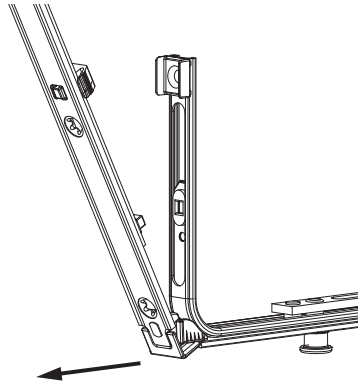

③

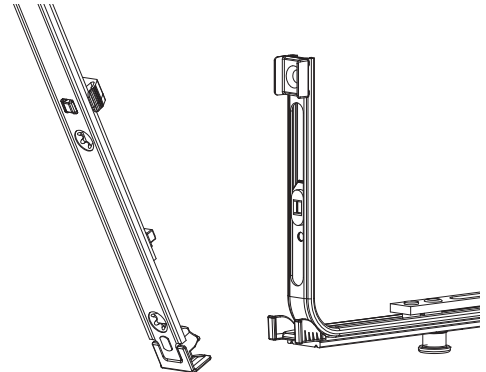



## 221907 - Stulpflügelgetriebe MM fix 1950 für 3 i.S. FFH 1.701-1.950 GM 1.050 Silber

### Zahnkastenverbindung

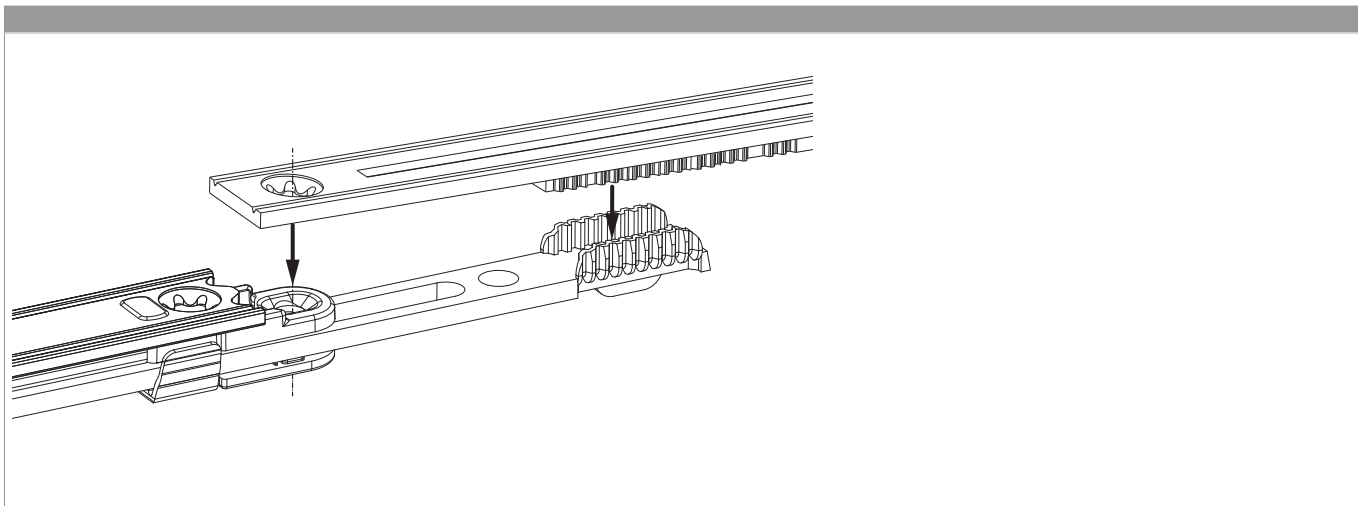

### Montage

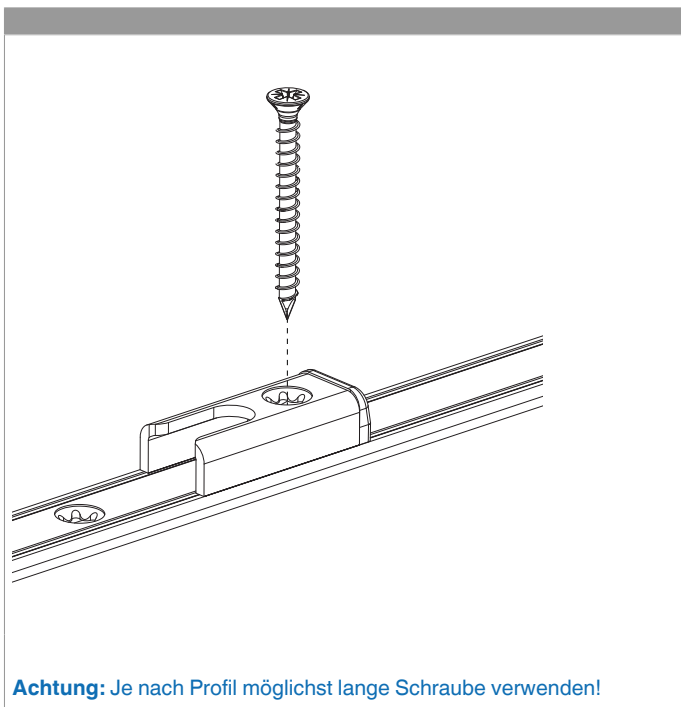



221907 - Stulpflügelgetriebe MM fix 1950 für 3 i.S. FFH  
1.701-1.950 GM 1.050 Silber

Gegenüberstellung der Kerbmarken

