

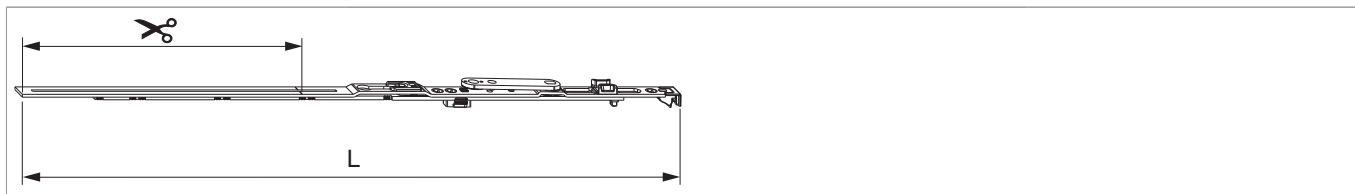

## 204827 - KD Scherenstulp MM 600 FFB 401-600 Silber

### Technische Zeichnung



		<b>L</b>					<b>No</b>
Silber	600	496,5	210	401 - 600	321 - 490	10	<a href="#">204827</a>

### Schraubpositionstabelle

<b>No</b>		1	2	3	4	5	6
<a href="#">204827</a>	3	18,5	170	180			

### Zapfensitztable

<b>No</b>		Z1
<a href="#">204827</a>	0	

### Stanzbild

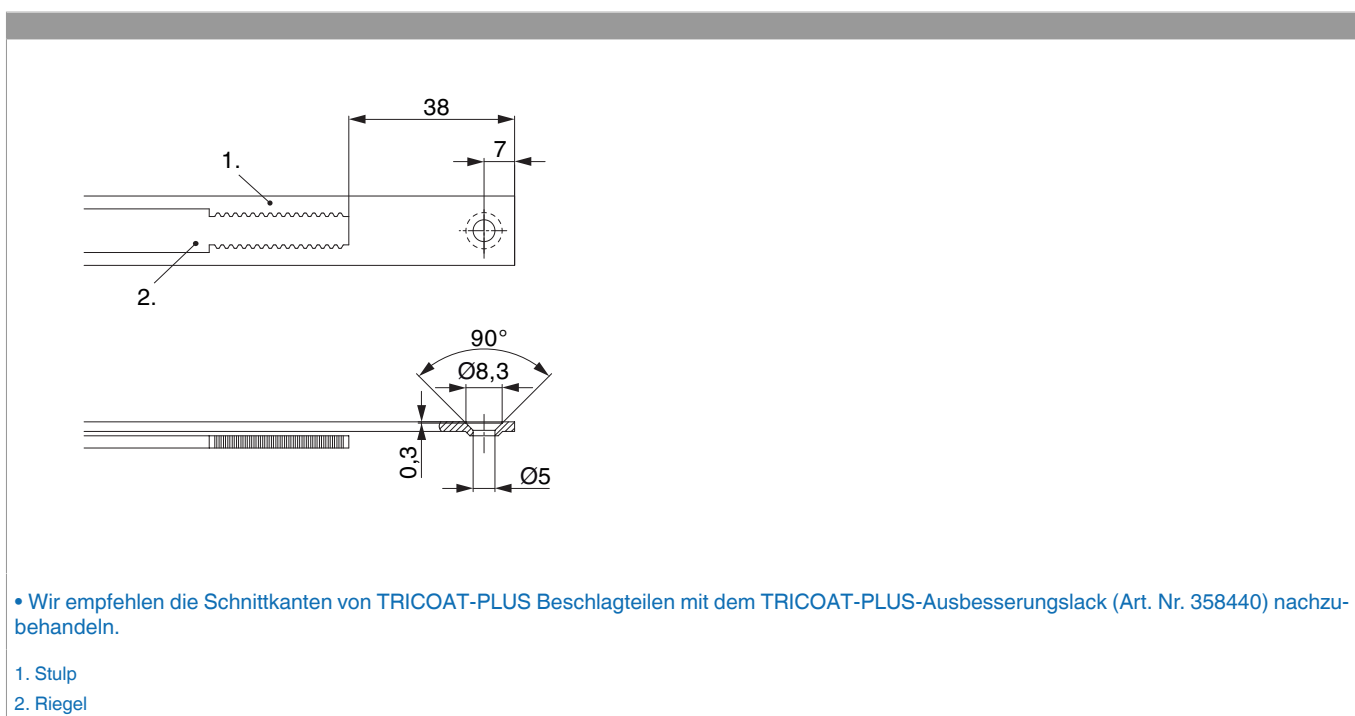

## Klipsverbindung

Klipsverbindung einhängen

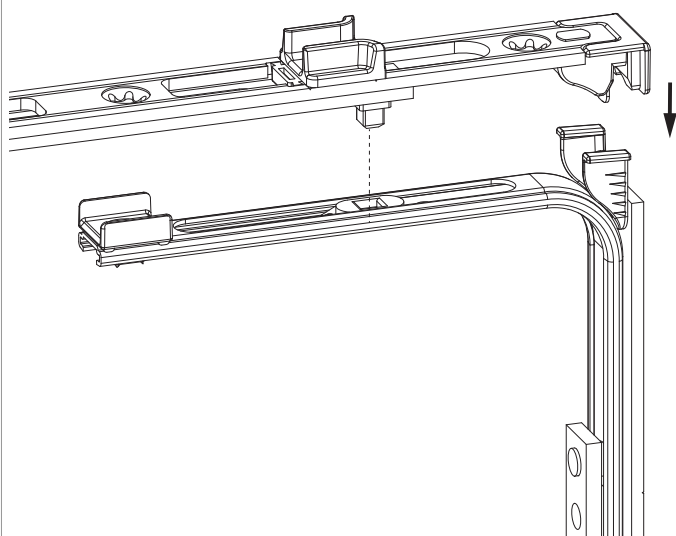

Klipsverbindung aushängen

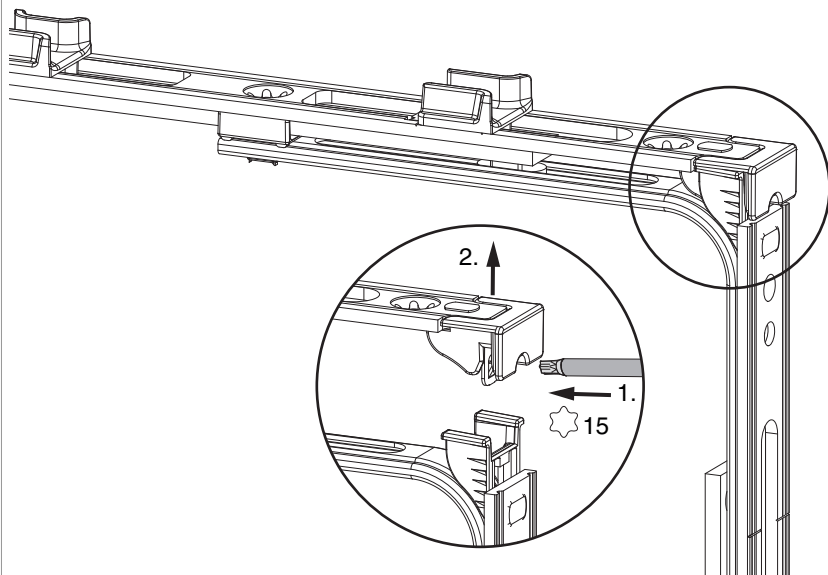



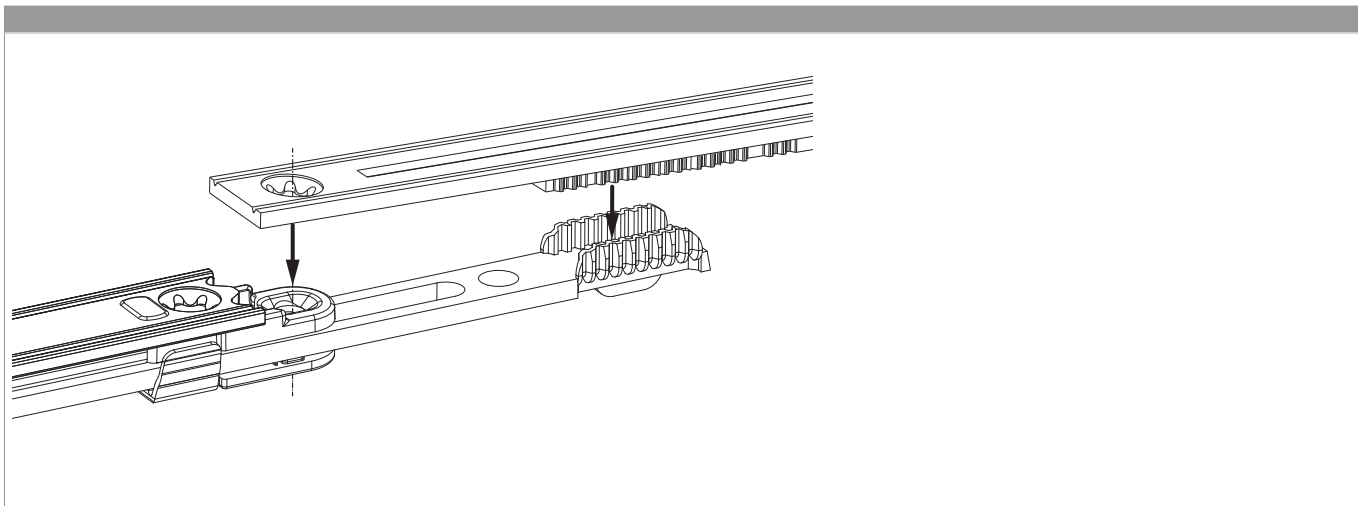

## Zahnkassenverbindung

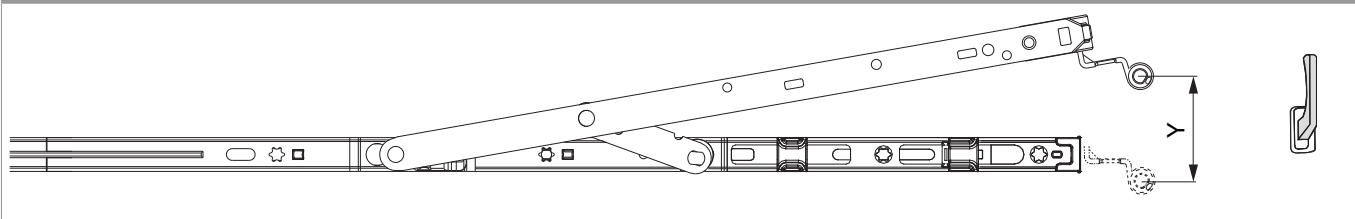

## Kippweite

Kippstellung



	Y
400	80
600	124
800	125
1050	127
1300	127

## Reihenfolge der Verschraubung

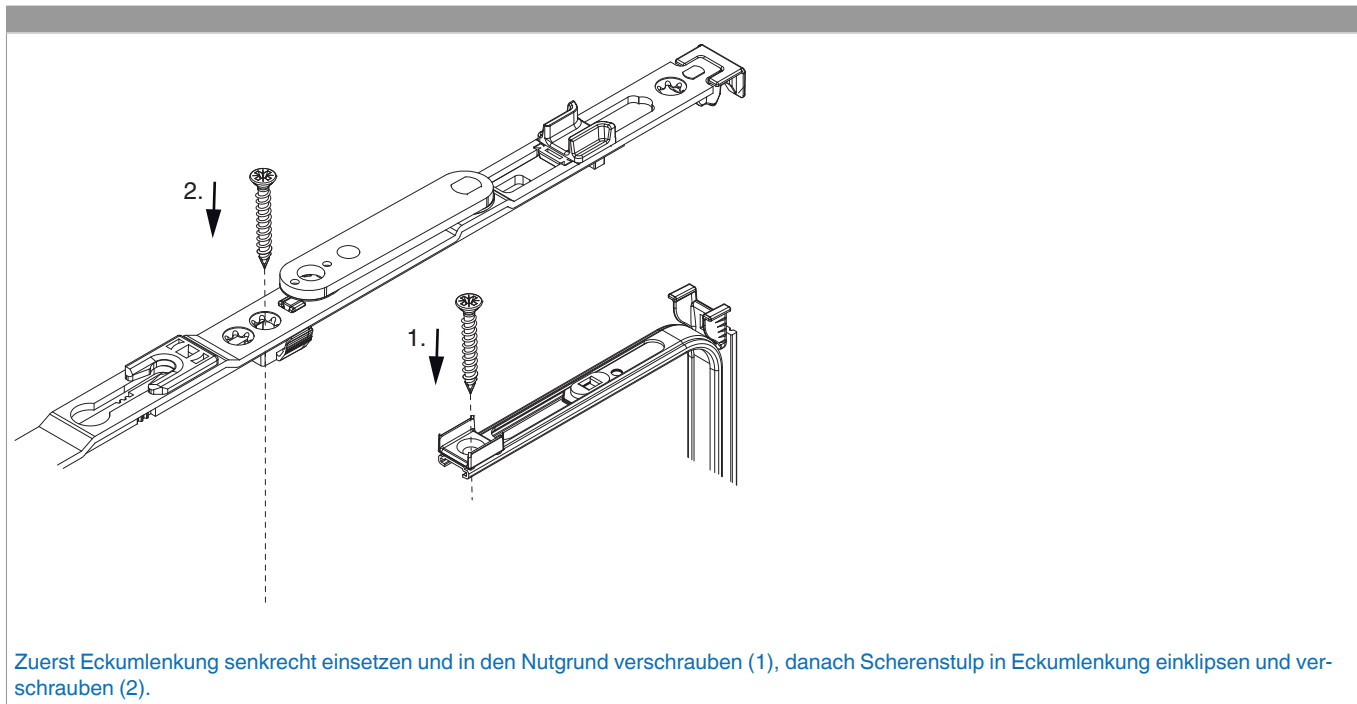

## Anpressdruckeinstellung

i.S Zapfen und Verschlusszapfen

