

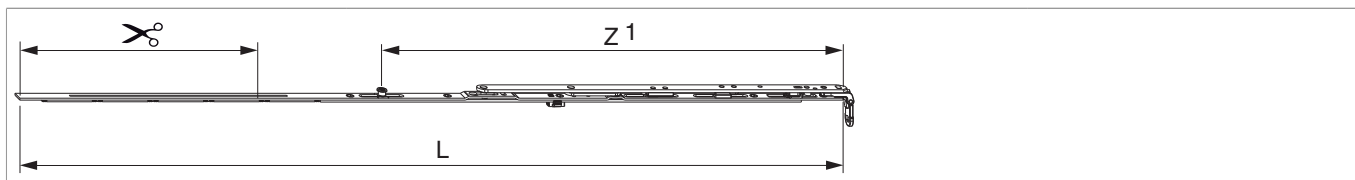

## 202318 - Schere für Schrägfenster MM 1050 mit 1 i.S. FFB 801-1.050 Silber

### Technische Zeichnung



		L					No
Silber	1050	946,5	275	801 - 1.050	80	10	202318

### Schraubpositionstabelle

No		1	2	3	4	5	6
202318	5	20	100	323	452	564	

### Zapfensitztable

No		Z1
202318	1	528

### Verwendungshinweise

- Mit diesem Artikel können Fensterelemente gefertigt werden, die bandseitig oben einen kleineren oder größeren Winkel als 90° haben.

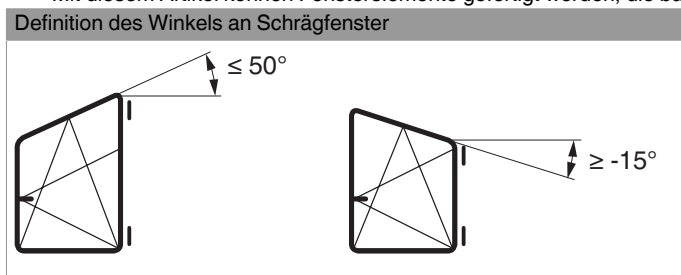

## Anwendungsdiagramme

Schrägfenster -1 bis -15°

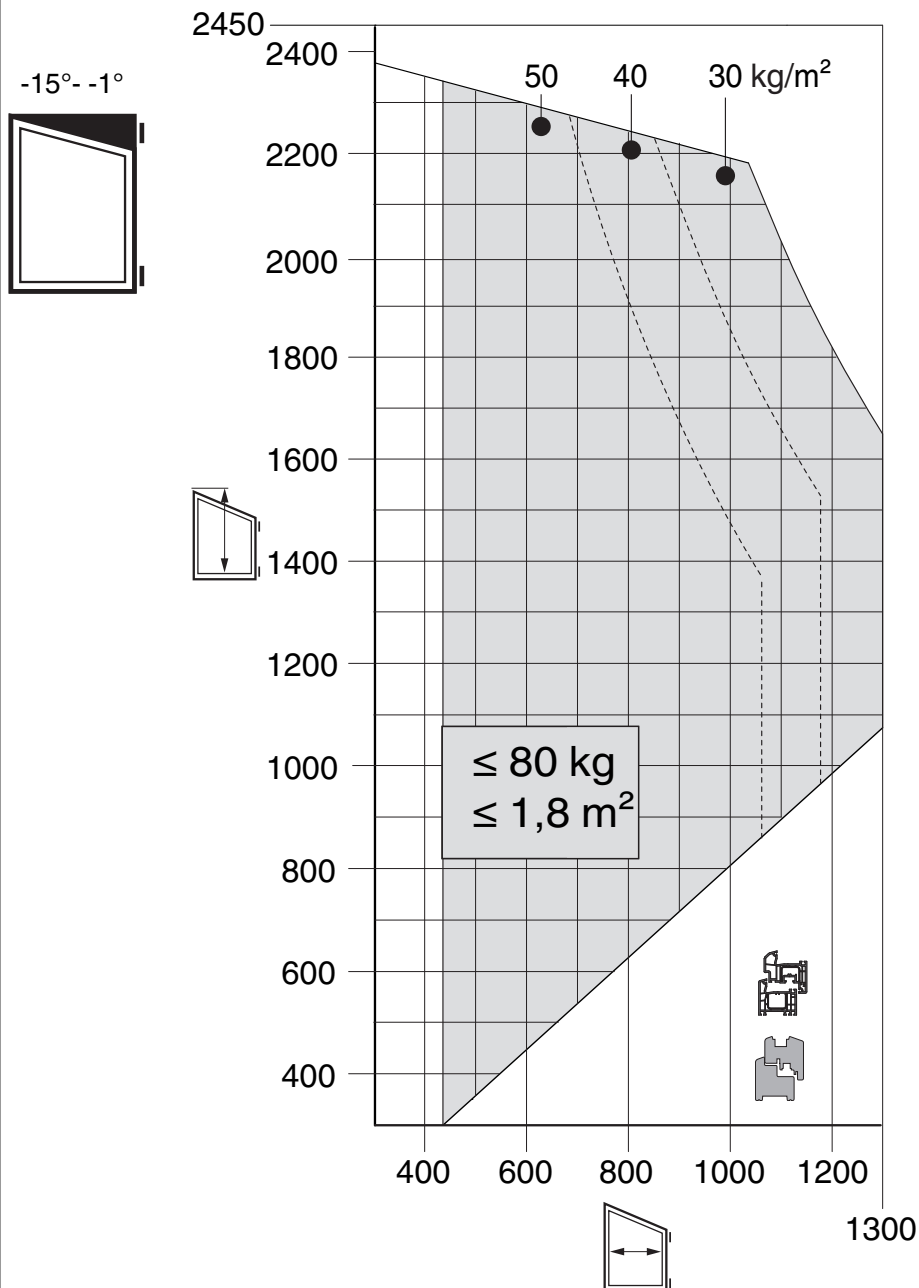

• Alle Hinweise zur Verwendung von Anwendungsdiagrammen in unseren Print- und Onlinekatalogen sind zu berücksichtigen!



# 202318 - Schere für Schrägfenster MM 1050 mit 1 i.S. FFB 801-1.050 Silber

Schrägfenster 1 bis 25°

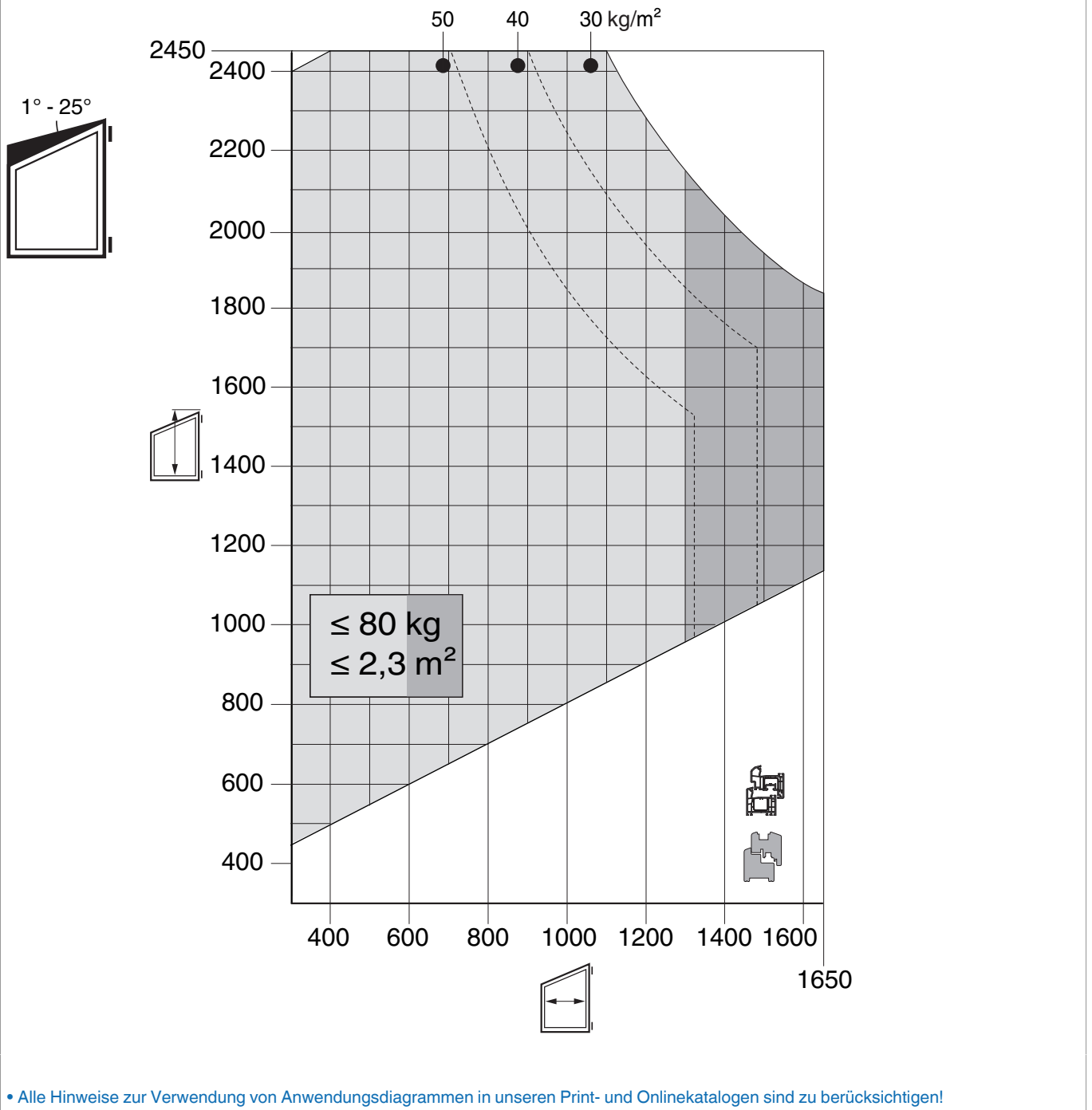



# 202318 - Schere für Schrägfenster MM 1050 mit 1 i.S. FFB 801-1.050 Silber

Schrägfenster 26 bis 40°

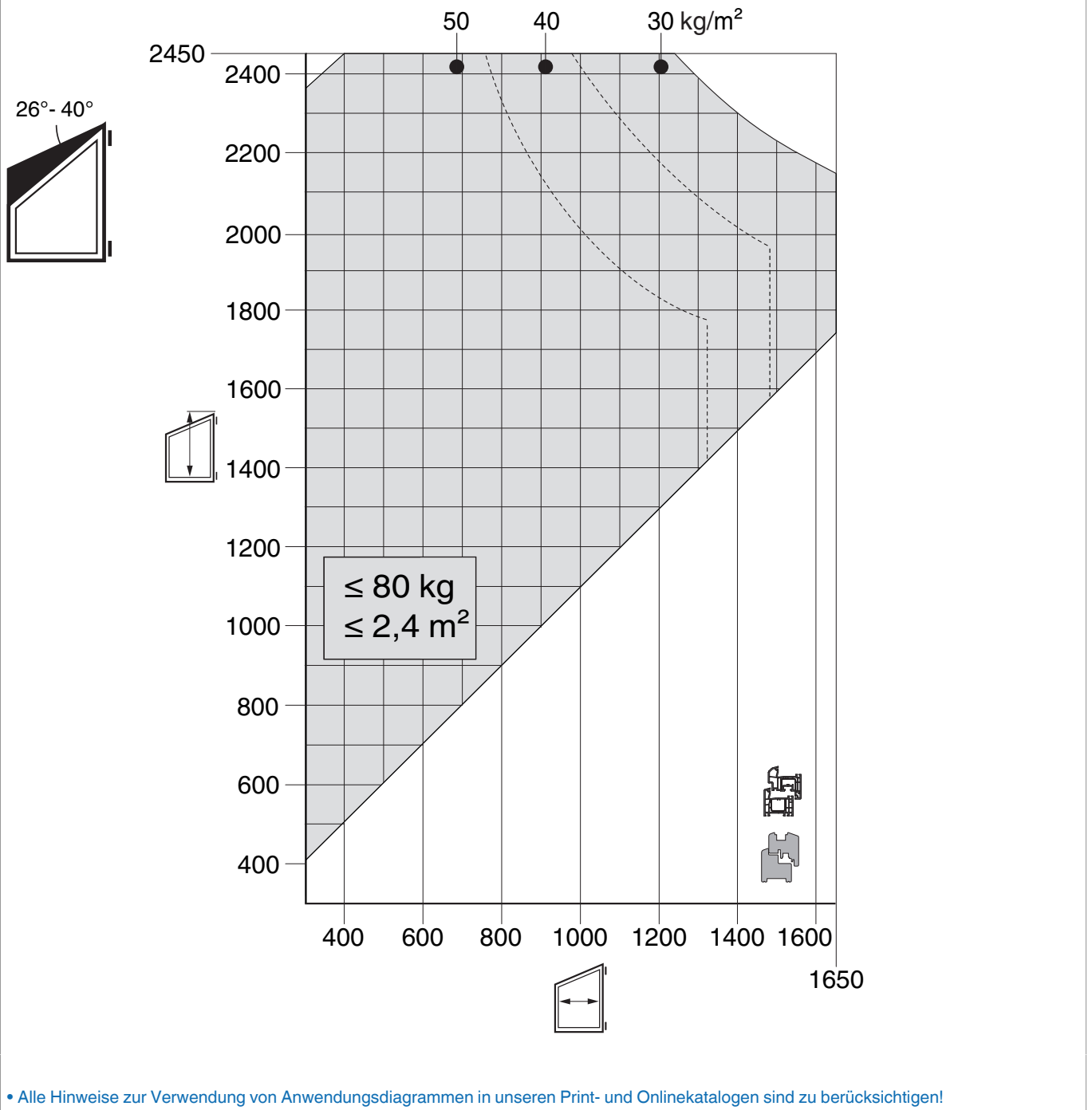



# 202318 - Schere für Schrägfenster MM 1050 mit 1 i.S. FFB 801-1.050 Silber

Schrägfenster 41 bis 50°





Tabelle zur Ermittlung der Scherengrößen

Differenz zwischen FFH (Bandseite) - FFH (GetriebeSeite in mm)	1250																			1632	1665	1698	1733	1786													
	1250																			50°	48,5°	47,5°	46°	45°													
	1150																				1595	1628	1662	1697	1733												
	1100																			49°	47,5°	46,5°	45°	44°													
	1050																			1524	1557	1591	1626	1662	1698												
	1000																			49°	47,5°	46,5°	45°	44°	42,5°												
	950																			1453	1487	1521	1556	1591	1628	1665											
	900																			1383	1416	1450	1485	1521	1557	1595	1632										
	850																			49,5°	48°	46,5°	45°	43,5°	42,5°	41°	40°										
	800																			1312	1345	1379	1414	1450	1487	1524	1562										
	750																			49,5°	48°	46,5°	45°	43,5°	42,5°	41°	40°										
	700																			1242	1275	1309	1343	1379	1416	1453	1492	1530	1570								
	650																			50°	48°	46,5°	45°	43,5°	42°	41°	39,5°	38,5°	37°								
	600																			1172	1204	1238	1273	1309	1346	1383	1421	1460	1500	1540							
	550																			1134	1167	1202	1238	1275	1312	1351	1390	1430	1471	1512							
	500																			1063	1097	1131	1167	1204	1242	1281	1320	1360	1401	1442	1484						
	450																			992	1026	1061	1097	1134	1172	1210	1250	1290	1331	1373	1415	1458					
	400																			49°	47°	45°	43°	41,5°	40°	38,5°	37°	35,5°	34,5°	33°	32°	31°					
	350																			992	955	990	1026	1063	1101	1140	1180	1221	1262	1304	1346	1389	1433				
	300																			851	885	919	955	992	1031	1070	1110	1151	1193	1235	1278	1321	1365	1409			
	250																			50°	47°	45°	43°	41°	39°	37,5°	36°	34,5°	33°	32°	30,5°	29,5°	28,5°	27,5°			
	200																			781	814	849	885	922	960	1000	1040	1082	1124	1166	1209	1253	1297	1342	1387		
	150																			734	778	814	851	890	930	971	1012	1055	1098	1141	1185	1230	1275	1320	1366		
	100																			47,5°	45°	42,5°	40°	38°	36°	34,5°	33°	31,5°	30°	29°	27,5°	26,5°	25,5°	24,5°	23°		
	50																			673	707	743	781	820	860	901	943	986	1030	1074	1118	1163	1208	1254	1300	1346	
	400	602	636	673	711	750	761	832	875	918	962	1006	1051	1097	1142	1188	1235	1282	1329	48,5°	45°	42°	39°	37°	34,5°	32,5°	31°	29,5°	28°	26,5°	25,5°	24°	23°	22°	21,5°	20,5°	19°
	350	566	602	640	680	721	763	806	850	894	939	985	1031	1077	1124	1170	1218	1265	1312	45°	41,5°	38,5°	36°	33,5°	31,5°	30°	28°	26,5°	25°	23°	22°	21°	20°	19°	18,5°	18°	
300	531	570	610	662	695	738	783	828	873	919	966	1012	1059	1107	1154	1202	1250	1298	41°	38°	35°	32,5°	30,5°	28,5°	26,5°	25°	23,5°	22,5°	21°	20°	19°	18,5°	17,5°	17°	16°	15,5°	
250	500	541	583	626	671	716	762	828	854	901	949	996	1044	1092	1140	1188	1237	1285	37°	33,5°	31°	28,5°	26,5°	25°	23°	22°	20,5°	19,5°	18,5°	17,5°	16,5°	16°	15,5°	14,5°	14°	13,5°	
200	472	515	559	604	650	696	743	791	838	886	934	982	1031	1079	1128	1177	1226	1275	32°	29°	26,5°	24,5°	22,5°	21°	19,5°	18,5°	17,5°	16,5°	15,5°	14,5°	14°	13,5°	13°	12,5°	12°	11,5°	
150	447	492	539	585	632	680	728	776	825	873	922	971	1020	1069	1118	1167	1216	1266	26,5°	24°	22°	20°	18,5°	17°	16°	15°	14°	13°	12,5°	12°	11,5°	11°	10°	9,5°	9°		
100	427	474	522	570	618	667	716	765	814	863	912	962	1011	1061	1110	1160	1209	1259	20,5°	18,5°	17°	15°	14°	13°	12°	11°	10,5°	10°	9,5°	9°	8,5°	8°	8°	7,5°	7°	7°	
50	412	461	510	559	608	658	707	757	806	856	906	955	1005	1055	1105	1154	1204	1254	14°	12,5°	11,5°	10,5°	9,5°	9°	8°	7,5°	7°	6,5°	6°	5,5°	5°	5°	4,5°	4,5°	4,5°		
	403	453	502	552	602	652	702	752	802	851	901	951	1001	1051	1101	1151	1201	1251	7°	6,5°	5,5°	5°	4,5°	4°	4°	3,5°	3,5°	3°	3°	3°	3°	2,5°	2,5°	2,5°	2,5°	2,5°	
	400	450	500	550	600	650	700	750	800	850	900	950	1000	1050	1100	1150	1200	1250																			
	Flügelalzbreite in mm																																				

Richtiges Lesen der Tabelle:  
738 = Maß der Länge der Schräge in mm  
28,5° = Neigungswinkel des Fensters

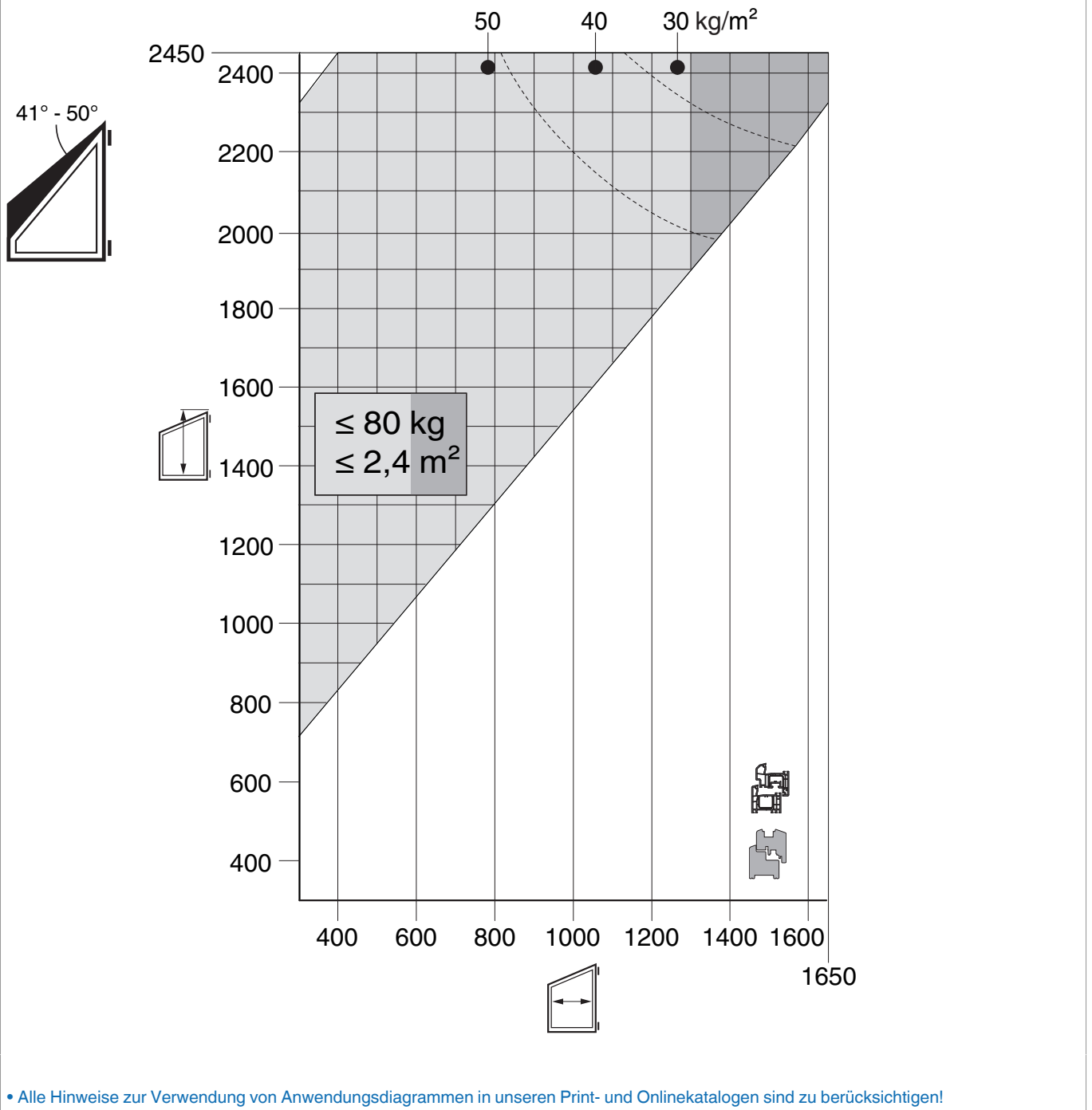

## Bohr- und Fräsbild

Beispiel PVC

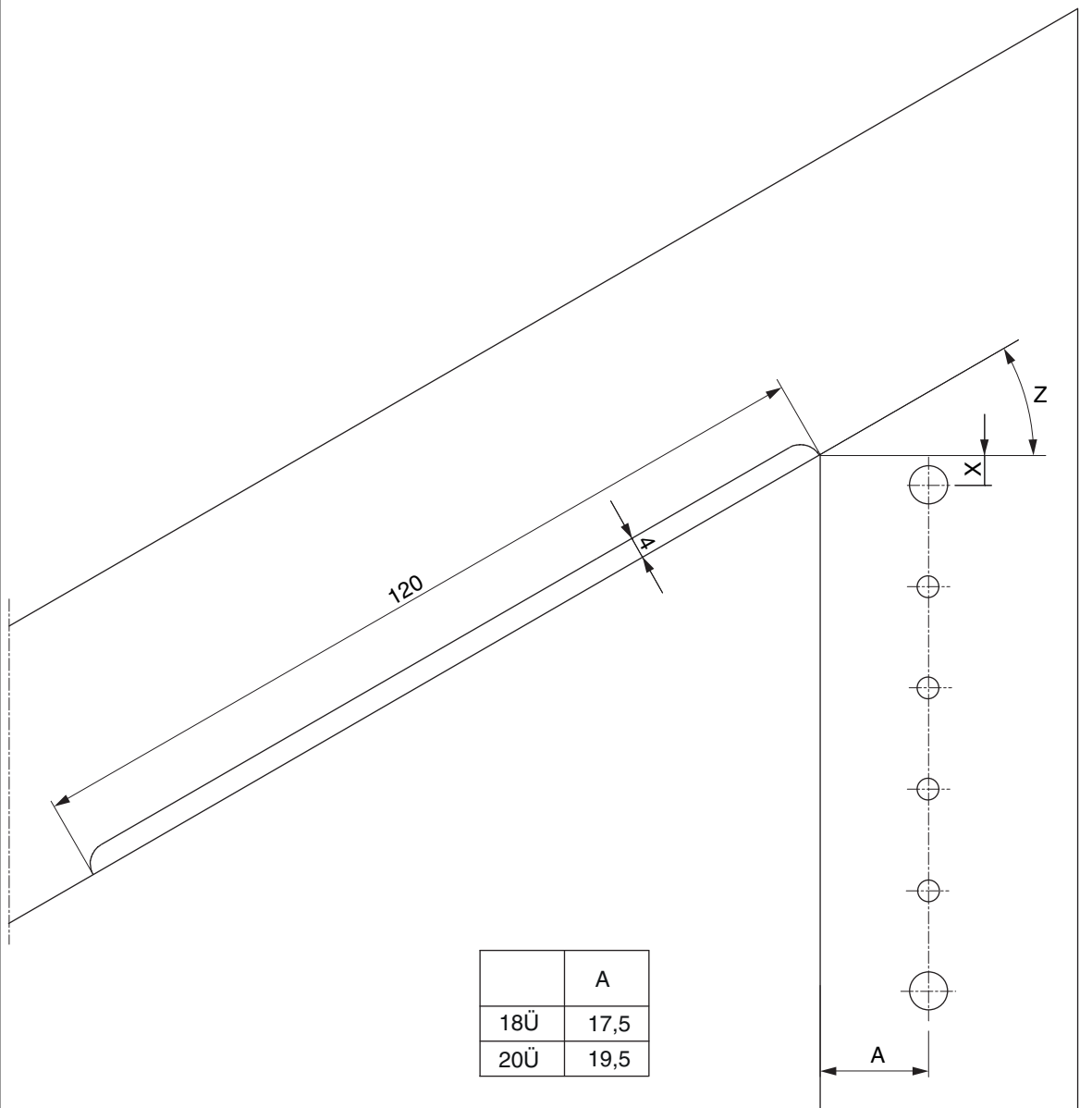

- Bohrbilder siehe Kapitel Scherenlager.
- Fräslänge und Frästiefe sind profilabhängig. Es ist darauf zu achten, ob das Profil diese Fräsung zulässt!



202318 - Schere für Schrägfenster MM 1050 mit 1 i.S. FFB  
801-1.050 Silber

PVC			
Neigungswinkel Z	Maß X bei 12L	Neigungswinkel Z	Maß X bei 12L
50°	15,2	15°	3,8
45°	12,4	10°	3,1
40°	10,1	5°	2,5
35°	8,3	0°	2,1
30°	6,9	-5°	1,8
25°	5,6	-10°	1,5
20°	4,6	-15°	1,4

Beispiel DT

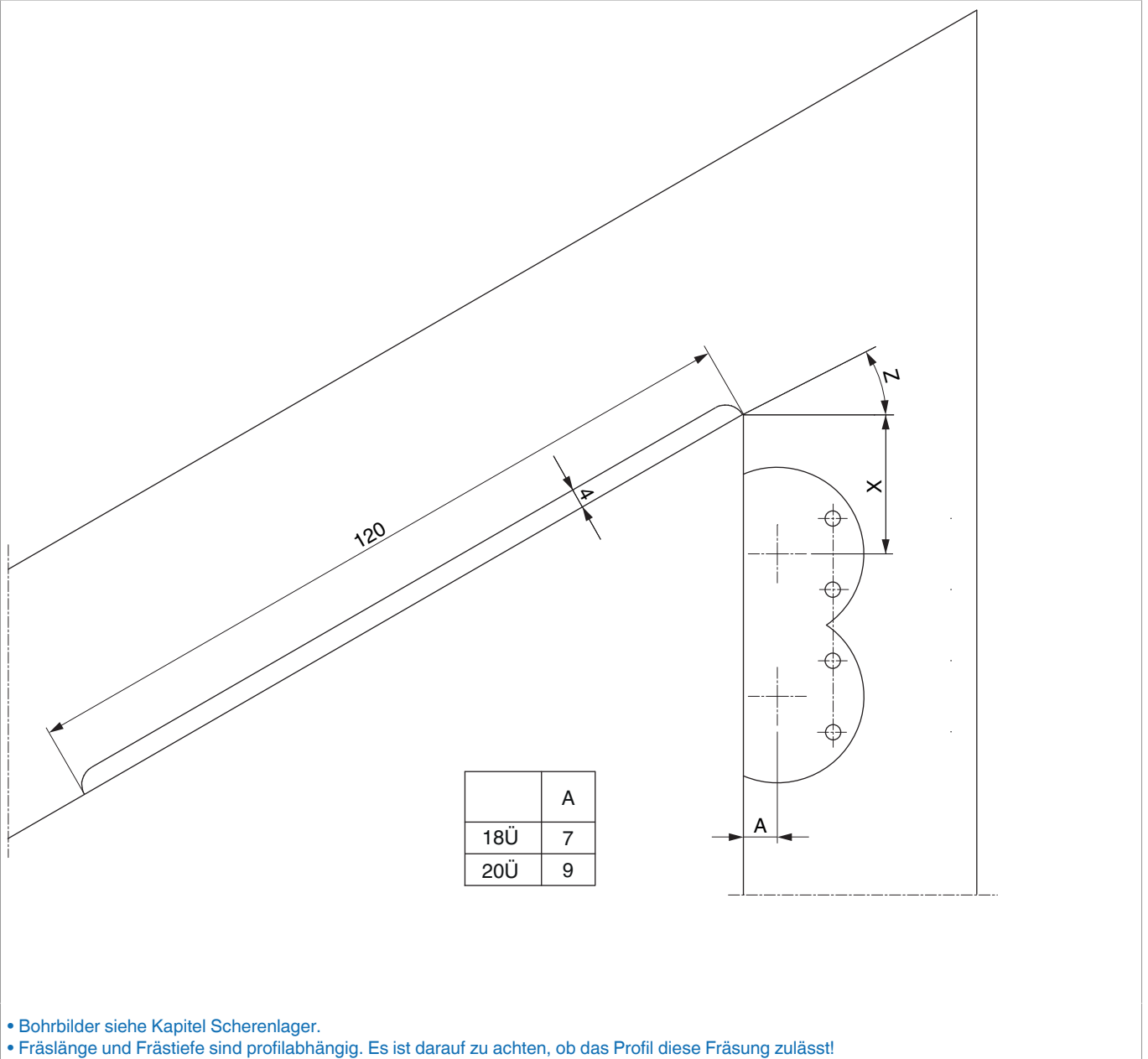

- Bohrbilder siehe Kapitel Scherenlager.
- Fräslänge und Frästiefe sind profilabhängig. Es ist darauf zu achten, ob das Profil diese Fräsung zulässt!



## 202318 - Schere für Schrägfenster MM 1050 mit 1 i.S. FFB 801-1.050 Silber

Beispiel DT

• **Achtung:** Bei Bedarf Flügelfalz-kante anfasen.

DT			
Neigungswinkel Z	Maß X bei 12L	Neigungswinkel Z	Maß X bei 12L
50°	36	15°	25
45°	34	10°	24
40°	31	5°	24
35°	30	0°	23
30°	28	-5°	23
25°	27	-10°	23
20°	26	-15°	23

### Stulpversatz

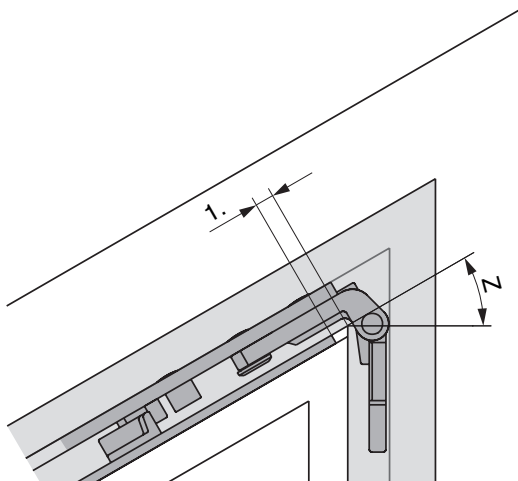

1. Stulpversatz ist der Abstand von Flügelfalz-kante bis Beginn Scherenstulp

Stulpversatz bei 12 mm Falzlufte PVC

Neigungswinkel Z	Stulp- versatz	Neigungswinkel Z	Stulp- versatz
50°	1	15°	3
45°	1	10°	3
40°	2	5°	2
35°	2	0°	2
30°	2	-5°	2
25°	3	-10°	1
20°	3	-15°	1



## 202318 - Schere für Schrägfenster MM 1050 mit 1 i.S. FFB 801-1.050 Silber

Stulpversatz bei 12 mm Falzluft DT			
Neigungswinkel Z	Stulpversatz	Neigungswinkel Z	Stulpversatz
50°	1	15°	2
45°	2	10°	2
40°	2	5°	2
35°	2	0°	2
30°	2	-5°	1
25°	2	-10°	1
20°	2	-15°	1

### Stanzbild

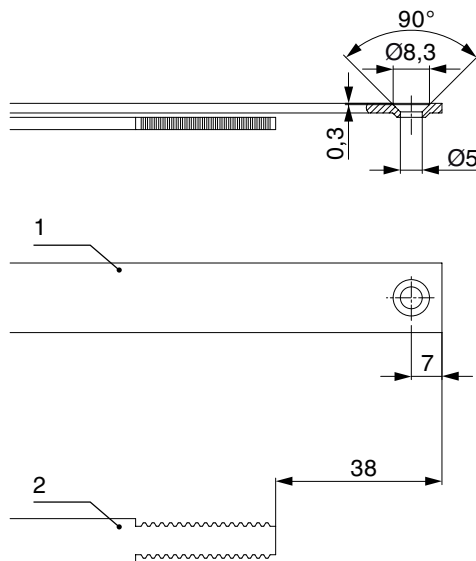

- 1. Stulp
- 2. Riegel



## 202318 - Schere für Schrägfenster MM 1050 mit 1 i.S. FFB 801-1.050 Silber

### Zahnkastenverbindung

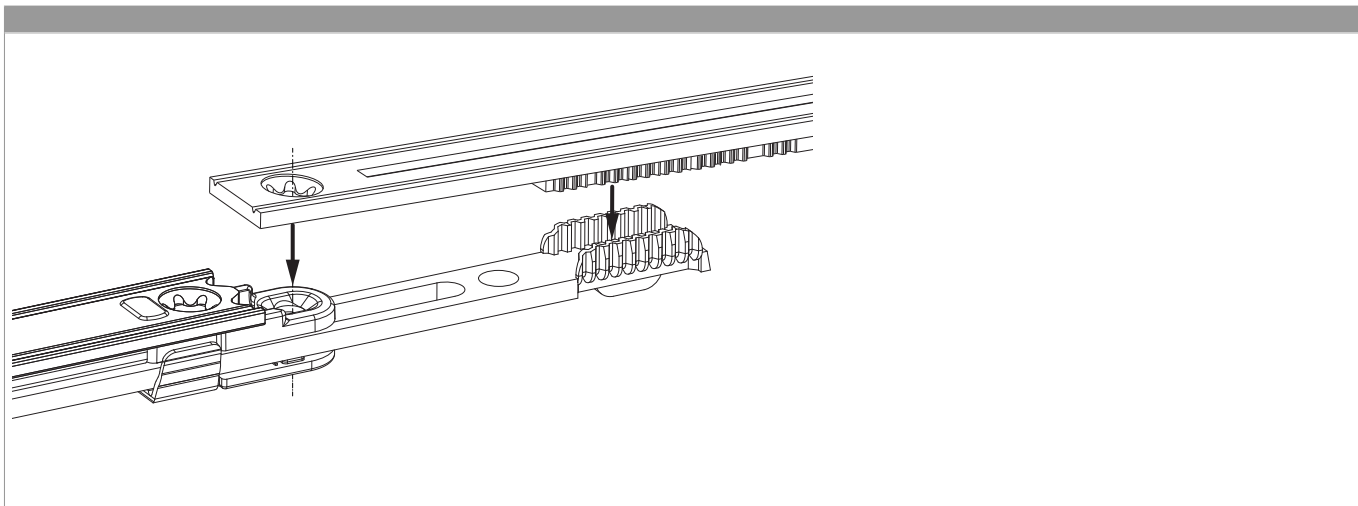

### Kippweite

Kippstellung

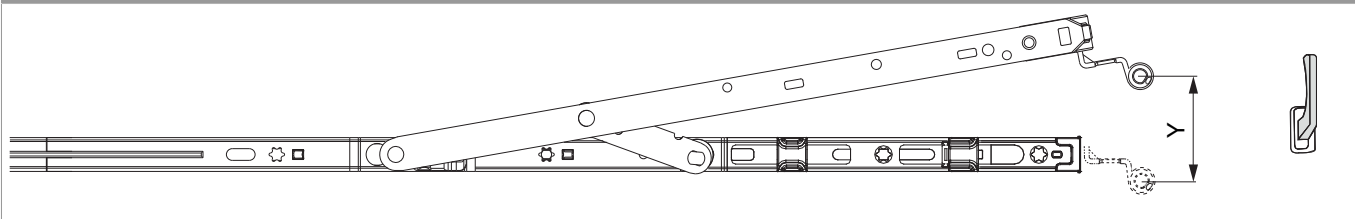

	Y
400	80
600	124
800	125
1050	127
1300	127

## Seiteneinstellung im Scherenarm

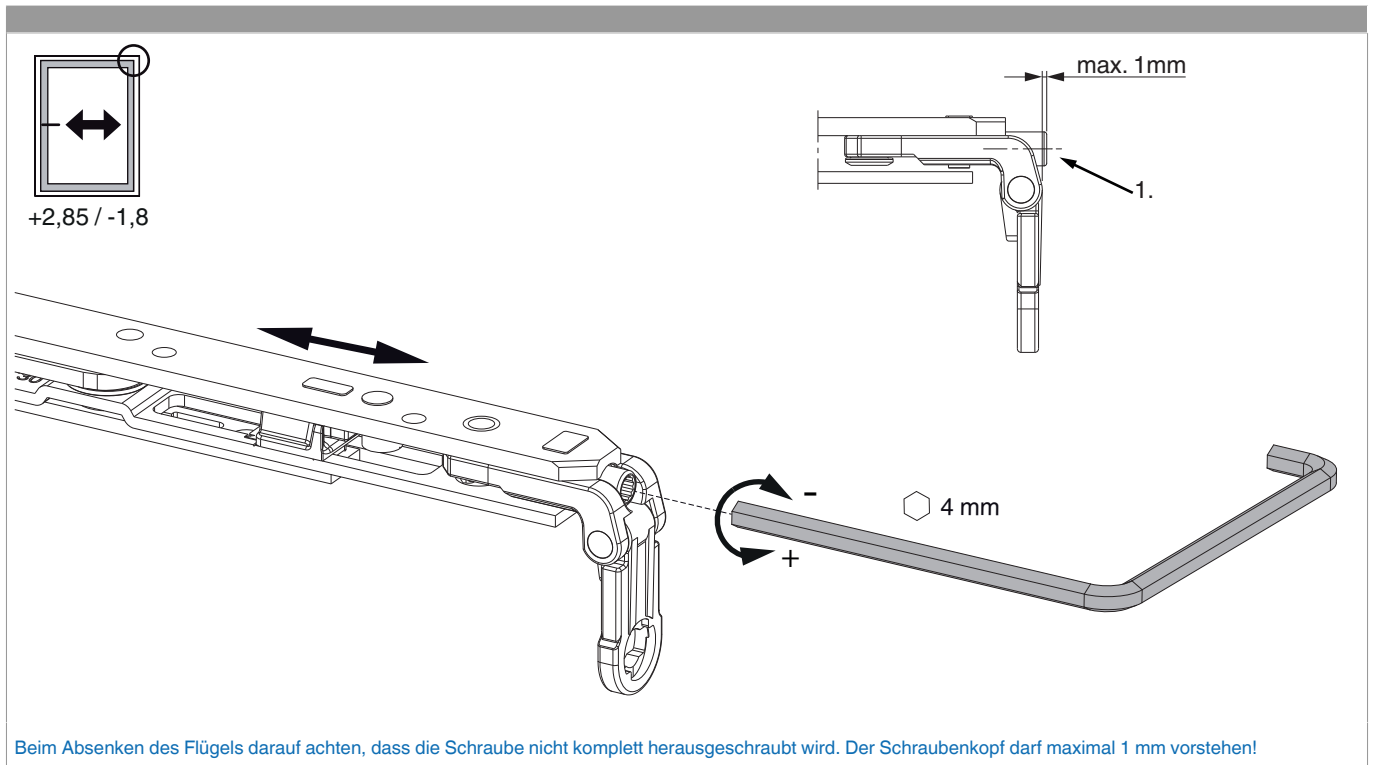

## Anpressdruckeinstellung

im Scherenarm

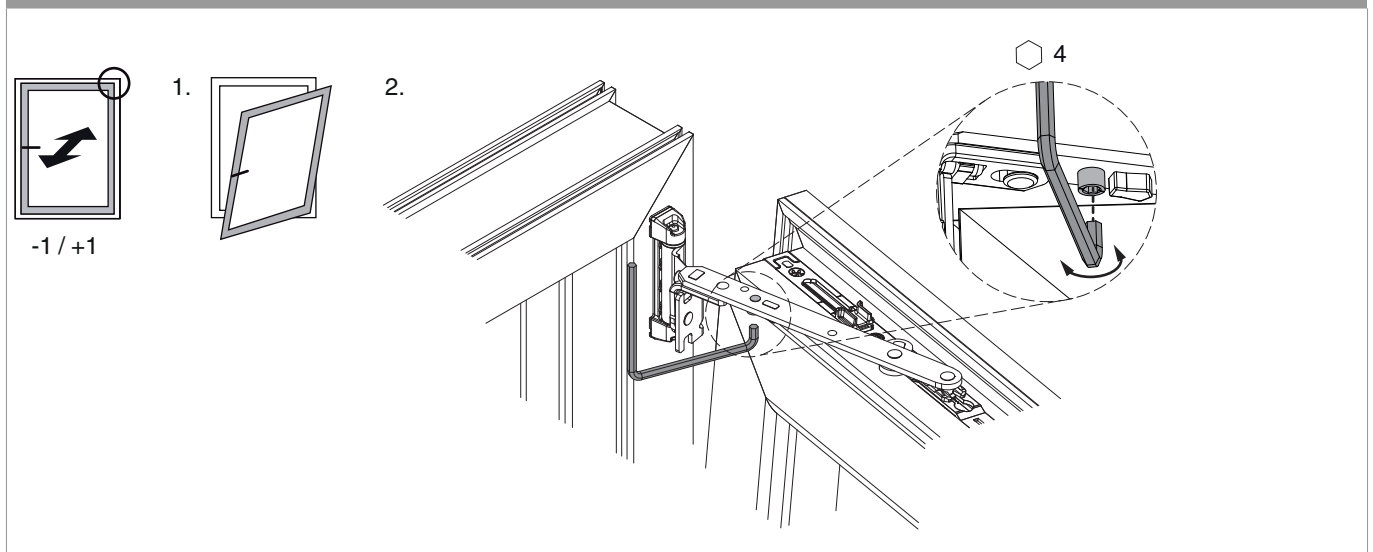



202318 - Schere für Schrägfenster MM 1050 mit 1 i.S. FFB  
801-1.050 Silber

i.S Zapfen und Verschlusszapfen

